

• SHOPFITTING SYSTEMS • IN-STORE DISPLAY • OUTDOOR DISPLAY •
SHELVING SYSTEMS • FLOOR COVERINGS • MERCHANDISING ACCESSORIES



SIGNWARE
SYSTEMS



Order online www.signwaresystems.co.uk

About Us

Established in 2006, Signware Systems is an integral partner for many UK retailers for their shopfitting requirements. Our aim is to ensure the end user gets reliable, quality products that enhance their ideas and compliment their displays and fixtures.

Our in-house research team, along with our partners across Europe and Asia manufacture, source and deliver, extraordinary products working in collaboration with you, our customer, and ensuring reliable and on time customer service.

The partnerships with our clients have developed to the point where Signware Systems is the first point of contact for innovative retail solution for all their business needs.

Working with metal, wood and plastic fabrication, we undertake many projects and challenges based on customer needs within their time and budget constraints. By offering bespoke services ranging from trouble shooting; design and manufacture, we achieve delivery of the products and solution on time and at the right price!

Signware Systems provides a range of products and services to major UK retailers in the following areas:

- Retail shelving and modular shelving systems
- Design tile flooring for retail outfits, industrial and commercial use
- Retail display systems and merchandising accessories
- Bespoke solutions for retail and commercial equipment



Some of our clients we work with are:



RIVER ISLAND



CHARLES CLINKARD
EST. 1924



Contents

■ Special Projects	4	■ Poster Holders & Grippers	46
■ Poster Frames	6	■ Print Holders & Leaflet Dispensers	50
■ Lockable Poster Cases and Notice Boards	14	■ Reel EZ Display System	52
■ Aluminum Textile Frames	18	■ Cable Systems	54
■ Light Box	20	■ Flooring Solutions	58
■ Pavement and Forecourt Signs	22	■ Shopfitting	60
■ Menu Boards	30	■ Advertising Mats	64
■ Brochure Stands	34	■ Shopping Trolleys and Baskets	65
■ Modular Information Stands	38	■ Accessories	66
■ Portable Promotional Display	42		

Special Projects

Signware Systems range of experience and network of partners enables us to tailor make and deliver special projects to customer's requirements. Starting from an idea to troubleshooting, leading to prototype and manufacturing to final roll out of multi store fit outs, the signware team will enable you to realise the outcome.

Signware Systems can tailor make and produce to the unique requirements of each customer by considering all variables from time constraints, cost implications to environmental concerns. Supported by our experienced in-house team with a network of manufacturing facilities in Europe and the Far East combined with global procurement experience, we will work closely with you through the life cycle of the project to delivery. We pride ourselves on each project to deliver the customers vision with long term durability and cost-effective benefits.

Our specialist network of manufacturing and procurement includes:
 Metal Work Fabrication
 Timber Solutions and Manufacturing
 Plastic and Acrylic Fabrication
 Merchandising and Display System Solutions

Signware Systems will develop your business ideas by forming a true partnership with its clients to establish a shared vision of the result and strive to fulfill that vision.

Bespoke Trolleys



Order online www.signwaresystems.co.uk

Merchandising Display



Design to Completion

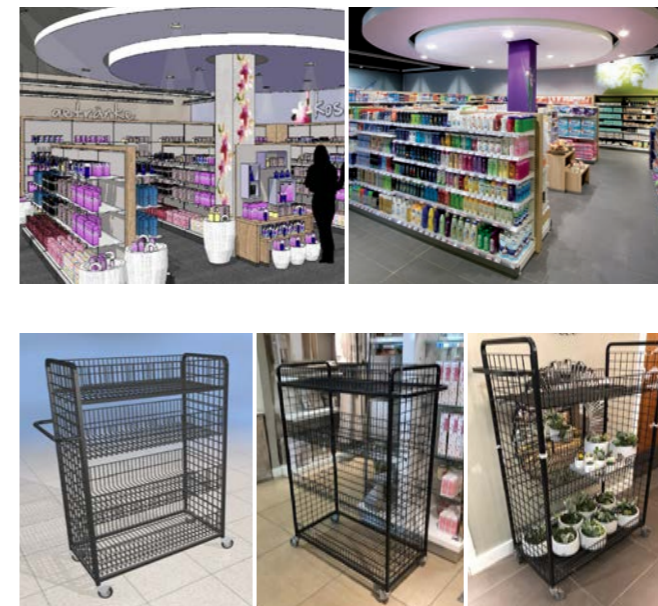

Order online www.signwaresystems.co.uk

In-House Design



WE WILL DELIVER YOUR IDEA

Poster Frames

- Bespoke RAL colours available and wood effect frames in most profiles
- 'Snap open, snap shut' clip frame mechanism
- Standard and custom sizes available
- Pre-drilled and individually boxed on wall frames
- Poster frames are supplied with 1 PET cover as standard

Our snap frames are supplied in a variety of sizes, colours and profile thickness. The unique front-loading aluminium snap frames makes it easier to change graphics. The snap frames are modern, attractive and come fully assembled with all the fixings at no extra cost to you. Your posters and custom graphics will be secure with the snap frames own 'Security by Intelligence' feature. This means when closed, all fixings and opening methods are hidden from view.

All frames are supplied with 1 UV anti-glare resistant poster PET cover and are sure to keep your posters from fading, keeping the frame safe and looking professional.

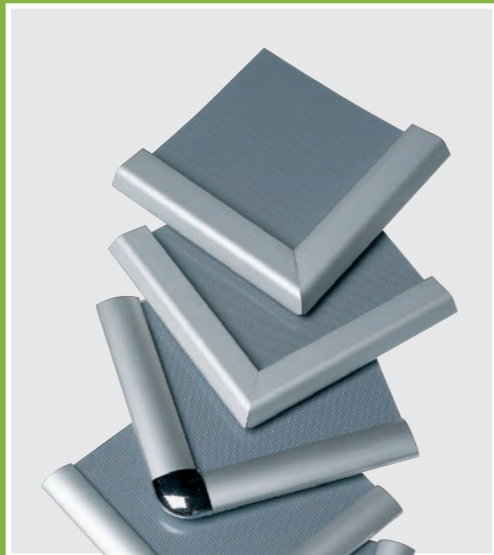

Order online www.signwaresystems.co.uk

15mm Snap Frames

Small and elegant 15mm profile, making the frame almost invisible and your poster stand out. Ideal for small posters and in a small tight wall areas.

Key Features:

- Thinnest frames on the market for small prints
- Ideal for showcasing prints

Colours Available



Sizes Available

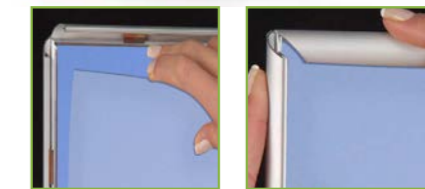
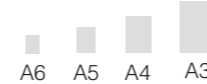

Product Code: SF15

25mm Snap Frames

Our most popular snap frame is the 25mm profile. This is ideal for all retail environments for display and promotional graphics and poster.

Key Features:

- Bespoke RAL colours available, wood effect, silver and gold
- Standard and custom sizes available

Colours Available

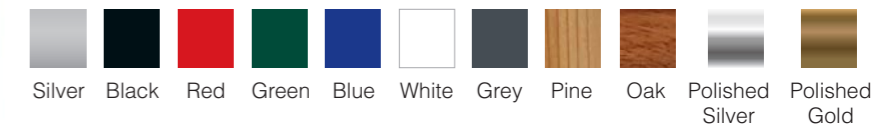

Sizes Available

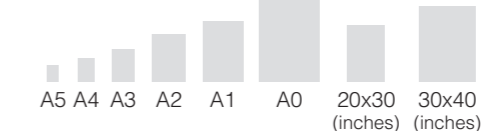

Product Code: SF25

Order online www.signwaresystems.co.uk



32mm Snap Frames

The 32mm profile snap frames are ideal for larger prints with the added grip to your poster. These frames are not water resistant but can be used outdoors. If using outdoors, we recommend printing on waterproof based inserts such as PVC.

Key Features:

- Larger profile offers more frame presence and better grip
- Ideal for large marketing and advertising

Colours Available



Silver Black Red Green Blue White Grey Pine Oak

Sizes Available

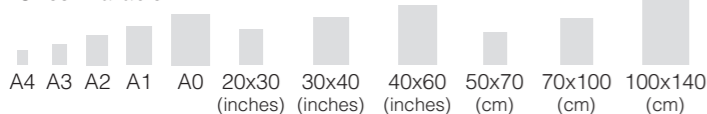

Product Code: SF32

Rounded Corner Snap Frames

Stylish rounded chrome corners have an elegant and modern finish. Your posters and custom graphics will be secure with the snap frames own 'Security by Intelligence' feature.



Product Code:
25mm: SF25/R
30mm: SF30/R

Key Features:

- Available in 25mm and 30mm in silver
- Black available in 30mm only
- Chrome rounded corners adds extra safety feature

Colours Available

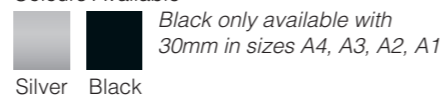

Sizes Available

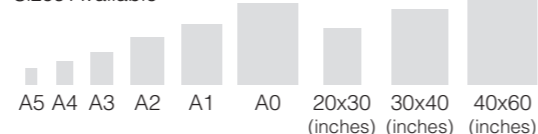

A5 only available in 25mm
40"x60" only available in 30mm

Weather Resistant Snap Frames

Weather resistant snap frames are available in silver as standard with mitred corners. Ideal for outdoor use to keep posters and all content free from adverse weather conditions and are elegant and eye-catching poster displays.

Key Features:

- Water resistant with an internal rubber seal
- Standard and custom sizes available in 25mm and 35mm profile
- For outdoor use

Colour Available



Silver

Sizes Available



25mm is not available in 40"x60"
35mm is only available in A0, 20"x30", 30"x40", 40"x60"



Product Code:

25mm: WSF25

35mm: WSF35



Window Snap Frames

These snap frames are perfect to display posters on windows. Outer frame is held up against the window with double sided tape on the front, which is covered by a decorative back profile and is water resistant. The back of the frame has a 'snap open, snap shut' mechanism for easy change of poster and is on the internal side of the window.



Key Features:

- 'Snap open, snap shut' profile for interchanging of posters
- Front profile, double-sided and water resistant
- Ideal for shopping mall windows

Colour Available



Silver

Sizes Available



A4 A3 A2 A1

Product Code: WIN25



Double Sided Snap Frames

Ideal for retail shop windows and office environments. Can be suspended from ceilings and lowered using a cable system. Hanging hooks supplied for showcasing the poster display on both sides to allow for it to be more accessible to see.

Key Features:

- Double sided for back to back advertising
- Free hooks for hanging
- Cable and fixtures are bought separately for ceiling suspension

Colour Available Sizes Available

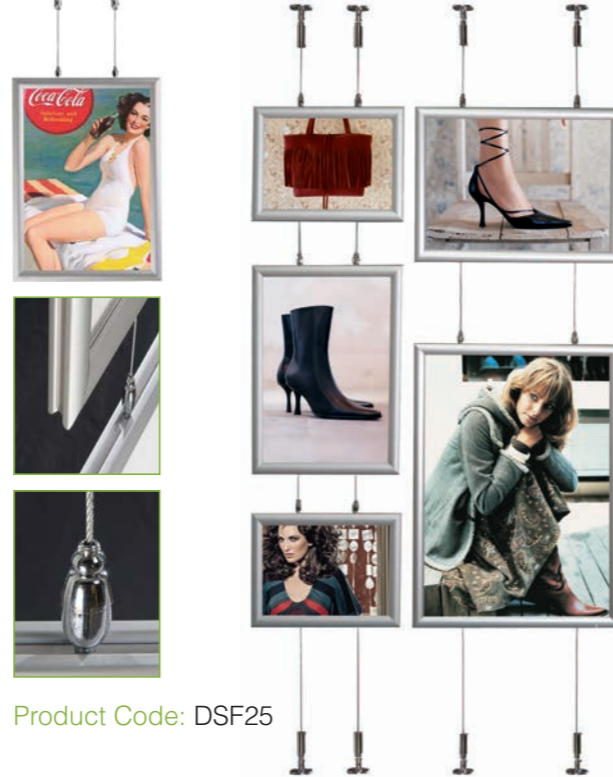

Product Code: DSF25

32mm Lockable Snap Frames

The lockable snap frame range is fully secure for indoor and outdoor use. The aluminium lockable snap frame is locked via a simple 'Allen Key' operation. If you are looking to display important information, then this product is ideal for you.

Key Features:

- 'Snap open, snap shut' clip frame with allen key lock mechanism
- Added security from vandalism

Colours Available



Sizes Available

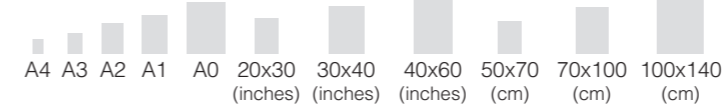

Larger sizes 50x70, 70x100, 100x140 only available in Silver and Black



Product Code: LSF32

Tamper Resistant Snap Frames

The clip snap frame includes a hidden layer of extra security. Each snap frame has additional springs fitted to deter even the strongest of grips with no clear access point displayed on the frame. The snap frame can only be opened with a lever tool supplied with the frames.



Product Code:
25mm: TRF25
44mm: TRF44



Key Features:

- Only available in silver and black
- Added security from vandalism
- Lever tool can also be purchased separately

Colours Available



Sizes Available

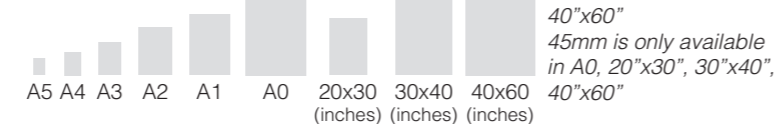

Order online www.signwaresystems.co.uk



Product Code:
SIF



Slide-In Frames

The 25mm slide-in aluminium frames operate with 'slide-in, slide-out' process of side loading or top loading. Frames can be easily mounted on the wall or hung from the ceiling using the clips provided.

Key Features:

- Only available in silver
- Supplied with PET covers to secure your prints
- Can be double-sided if hung from ceilings

Colour Available Sizes Available (Portrait & Landscape)

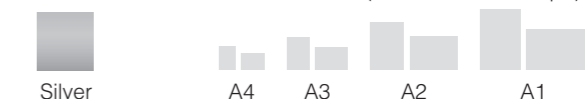

Order online www.signwaresystems.co.uk

Counter Slide-in Frames

New desktop slide-in frame, which can also be used as a picture frame, are supplied with 2 PET covers to protect the prints. Also shipped with plastic wick and available in small sizes only with double-sided tape on the bottom base.



Product Code: CSF

Key Features:

- Available in small sizes and landscape only
- Side loading with adhesive thin base
- Only available in silver and can be double sided
- The product has a rubber seal for outdoor use

Colour Available



Sizes Available



Opti Frames (Free Standing)

These aluminium desktop frames are great for displaying messages and posters, as well as photos for personal use. The Opti frames are available in 14mm profile in colours black, silver, white, red and blue. The 25mm profile option is available in black or silver and size A4 only. The frames are standard with soft corners and can be wall mounted. The frames can be portrait or landscape.



Product Code:
14mm: OSF14
25mm: OSF25

Key Features:

- Supplied with wall hangers, fixings and holes on the two long sides
- 25mm is suitable for silk screen printing
- Suitable for tables, desk and counters with counter support hinged leg

Colours Available



Sizes Available



25mm is only available in Silver or Black in A4

Snap Frame Accessories

Lever Tool

Specially made for opening the tamper resistant snap frame, the lever tool allows easy opening to change your display quickly and easily. The nature of the tamper resistant snap frame means the added security and the frames cannot be opened without any other method.



Product Code:
25mm LT-25
44mm LT-44

Special Allen Key

A special allen key is used to open the lockable snap frames making the frames more secure. The unique frames have a special locking system in place, whereby all sides of the lockable frames are sequentially closed and then locked.



Product Code:
SAK



Anti-Glare Replacement Covers

These anti-glare PVC replacement cover sheets are sold in packs of 2 and are suitable to fit most of our snap frames and A Board pavement signs. These high-quality plastic covers are designed to keep your posters professional looking and are supplied pre-cut to specific sizes. Please check dimensions carefully before ordering.



Product Code:
RC

PRICES
ON OUR
WEBSITE

Lockable Poster Cases and Notice Boards

Poster display cases and notice boards offer a safe way to display posters in most environments.

For indoor and outdoor use, our poster cases are secured with a simple lock and key mechanism making them ideal for all weather conditions.



Our notice boards are ideal for high traffic indoor messaging and bulletin boards.

- Available in felt or magnetic
- Have an aluminium frame
- Various sizes available

Poster cases are also available in felt and magnetic cases.

- Bespoke RAL colours available
- Push clip mechanism to secure your poster
- The profile width is 45mm and depth is 30mm
- Cost effective outdoor marketing



Order online www.signwaresystems.co.uk

Lockable Poster Case

Our lockable poster cases are ideal for indoor and outdoor use. They use a key and lock system as well as being water resistant. Changing the display is easy with the front-loading system and it can be fixed in either portrait or landscape.

The premium addition features a better lock system, internal rubber seal and flat front face profile as extra benefits to the standard lockable poster case.

Key Features:

- Indoor and outdoor cost-effective marketing
- Ridged front face profile with standard lock system **(on standard poster case)**
- High quality barrel lock system, internal rubber seal and flat front face profile **(on premium poster case)**
- Supplied fully assembled with mounting hardware



Product Code:
Standard: LPC
Premium: PPC

Colours Available (Standard and Premium)



Sizes Available (Standard and Premium)

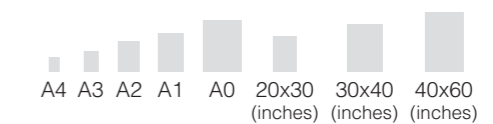

Larger Sizes Available
(Standard only in Silver or Black):

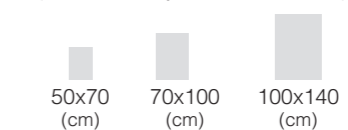

TOP
SELLING
PRODUCT

Order online www.signwaresystems.co.uk

Magnetic Lockable Poster Case

Our magnetic lockable cases provide the highest quality of security and a safe way of displaying your notices and content inside. The magnetic cases are suited for indoor and outdoor use and they are water resistant to prevent liquid damage to the content. All sizes are supplied with two locks, except the 4xA4 which has a single lock. The dry wipe magnetic surface makes dry wipe markers suitable to use.



Product Code: MLC

Key Features:

- Silver as standard frame profile and can be mounted portrait or landscape
- Easy content change with key lock mechanism
- 2 mounting arms, 2 handles, 1 key set single variation and fixing set
- Each unit has a free set of magnet buttons

Colour Available	Sizes Available			
Silver	4xA4	6xA4	9xA4	12xA4

Felt Lockable Poster Case

The felt lockable poster case provides high quality security and a safe way to display all notices and contents. These are water resistant and great for both indoor and outdoor use. The inner felt is available in blue and grey with an outer casing of silver anodised. Available in a range of sizes, stylish and attractive with a lock and key system. All sizes are supplied with a double key except 4xA4, which has a single key.



Product Code:
Standard: FPC Premium: PFC

Key Features:

- Ridged front face profile with standard lock system (**standard case**)
- Felt backing that welcomes both velcro and pins
- Profile width is 45mm and depth is 36mm
- Supplied with wall plugs and screws for wall mounting
- High quality barrel lock system, flat front face profile and internal rubber seal (**premium case**)
- Full range of A sizes and inch sizes available in the premium model

Colours Available	Standard Sizes Available			
Blue Grey	4xA4	6xA4	9xA4	12xA4

Premium Sizes Available			
A4	A3	A2	A1
A0	20x30 (inches)	30x40 (inches)	40x60 (inches)

NOTICE BOARDS

Magnetic Board

Available exclusively in silver, the magnetic board comes in two sizes 60x90cm and 90x120cm. This board is great for writing critical information and messages for high traffic public areas. These magnetic boards have a dry wipe magnetic surface which is suitable for both dry wipe pens and magnets. The notice boards are easy to mount and practical for everyday information display.

Key Features:

- Can be used as a magnetic board or wipe board
- Silver aluminium frame is attractive and stylish
- Easy message changes with the aid of pens and magnets

Colour Available	Sizes Available	
Silver	60x90 (cm)	90x120 (cm)



Product Code: MB

IDEAL FOR
SCHOOLS &
OFFICES



Felt Pin Board

Our felt pin board is a notice board with a velcro background and a silver frame. This board is great for displaying messages or promoting information and are available in two sizes, 60x90cm and 90x120cm in two colours, blue and grey.

Key Features:

- Quick and easy notice change
- Ideal for fast moving retail and office environments
- Felt backing, suitable for velcro and pins

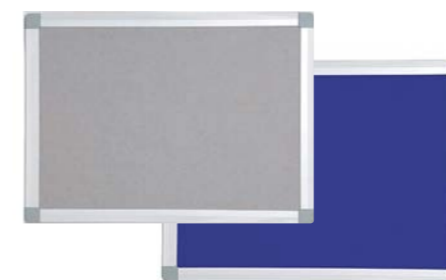

Product Code: FPB

Colours Available	Sizes Available	
Blue Grey	60x90 (cm)	90x120 (cm)



Aluminum Textile Frames

Aluminum **Textile Frames** are modern, attractive and are easy to use. The frames are ideal for advertising and easy and quick to change graphics. The aluminum **textile frame** can be mounted quickly and easily and are available in various models as well as illuminated and non illuminated versions.

Key Features:

- Available in either silver anodised or powder coated finish
- No tools required to change graphics
- Vibrant, hi-resolution graphics printed on textiles
- Dimmable, low voltage LED option available on some models
- Double sided units can be pole mounted (floor to ceiling) or free standing (bolted for safety)



Retro Fit Texsign Profile

This profile can just as easily change an existing, vinyl decorated, acrylic faced lightbox into a vibrant, colourful soft graphic system. Why not turn a dark recess or a window frame into a useable advertising space? The retro fit design profile allows fabric to be mounted on existing traditional units.



24mm Texsign Frame



This profile can simply be used as a standard, non-illuminated graphic display system with no backing. Alternatively used for hiding unsightly brickwork or save the cost of plaster-boarding. Units can be illuminated with a LED light sheet as a backing if required.



60mm Texsign Frame

The ultimate profile to suit many environments using dimmable LED's to enable you to balance the light level according to the detail on the print and the surroundings. This model has a slim profile and supplied with 3mm hoarding backing.



Other Profiles available:

Retro fit 120mm profile with dimmable LED's, benefiting from an acrylic or voile diffuser (depending on lighting option). Take an old slimline light box and re-work using our 120mm texsign profile to create a fabric frame.



170mm economy Texsign profile is a deeper profile without dimmable lighting and the backlighting is achieved through standard fused gear trays, but opal polycarbonate is used as a diffuser and to ensure operator safety.



180mm double sided Texsign profile can be post mounted, free standing or stand alone. This product looks great in any format. Using the same lighting options as the 120mm texsign box, it is great either in a shop window or as part of a dividing wall concept. One price, twice the advertising space!

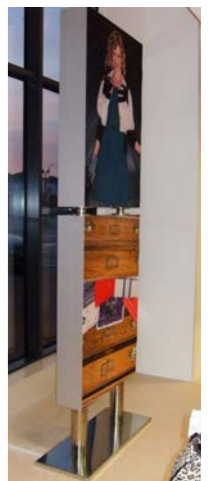

FRAME
YOUR
VISION

Light Box

The light boxes vary from LED to backlit light box for illuminating signs to help display your company logo or products and promotions. The light boxes are available in a range of sizes and in various colours.

The profile of all the models allows for a clean and professional look to illuminate your graphics whether it is Indoor or outdoor, creating a powerful marketing tool with cost effective benefits.



Static marketing through bright light, attracts customers attention by creating a visually more attractive advertisement. Benefit to using light boxes is the option to run the advertisement throughout the day or night. Illuminate and showcase your company or products with our state of the art light boxes for all your surroundings.

Smart LED Lightbox

The Smart LED light box can be single or double sided and uses a snap frame mechanism making it easy to change the graphics. This efficient light box saves up to 60% of energy cost and only requires a low voltage to operate, it also comes with an on and off switch built in for easy indoor use.



Double sided not available in A0

Key Features:

- Bright Led light marketing to catch customers attention
- Popular with cosmetics and leisure industry
- Double sided available on request to allow a two-way advertising for your product
- Can be mounted on high ceilings or windows



Single Sided **Double Sided**

Product Code: SLED-S Product Code: SLED-D

Convex Lightbox

For a more stylish and unique look, our attractive convex lightbox is a single-sided display unit for internal wall mounting. Supplied with a tube lighting to provide an even illumination across the convex surface and has a clip frame feature to make it easier to change and display graphics.

Key Features:

- Anti-glare PET poster cover included to protect your marketing
- Ideal for fashion and cosmetic retailers
- Futuristic convex shape adds extra dimension to graphics
- Best size and shapes for around pillars as an ideal marketing tool



Product Code: CLB

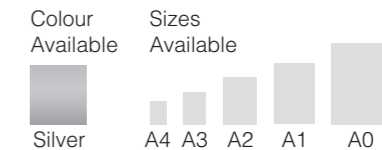

Product Code: EXTLB

External Lightbox

Our 'External light box' is weather resistant and watertight so ideal for outdoor use. The frames are strong and secure, making it vandal resistant. Using LED technology to save energy, the bright illumination makes graphic or sign applications such as: shop fascia signs, outdoor advertising posters, restaurant menus and other promotional signage highly visible and eye catching. (Please call with your specification and mounting options for pricing).

Key Features:

- Outdoor illuminated advertising marketing tool
- Saves energy cost compared to fluorescent technology on LED versions
- Large models and deep profile available, please enquire



Pavement and Forecourt Signs

- Built for durability and outdoor conditions, these boards are very stable, easy to operate and to change graphics
- Outdoor signs are portable, attract passing pedestrians and motorists, very lightweight and easy to move and store
- Modern and attractive design ideal for most business styles and an excellent marketing tool
- Pavement signs have locking side arms for stability
- A Boards have steel frames, galvanised steel back panel and standard UV anti-glare PET front cover
- Tubular A Boards are supplied with a UV anti-glare PET magnetic front cover
- Forecourt signs and Waterbase signs are a unique poster display unit for areas of increased footfall



The double-sided A Board units operate with easy to use poster changing features. The steel frames, steel back panels and the PET poster covers are all fully recyclable. Ideal for outdoor promotion in high traffic areas and are a cost-effective advertising tool.



With all our A Boards and Tubular A Boards it is advised that your poster display or literature for these boards are on a water resistant based paper or PVC type material, to best protect them from sustained weather conditions. In adverse conditions, it is recommended to move your sign units to a more covered area to protect from long term damage.

Order online www.signwaresystems.co.uk



Key Features:

- Available in various colours and sizes
- Bespoke RAL colours available

Colours Available



Sizes Available

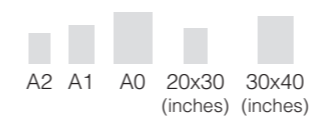

A Board

Ideal way for advertising or promoting events to attract potential customers. Pavement signs are very attractive and competitive cost-effective outdoor marketing tool. With a snap frame mechanism, these units offer a very quick and easy poster changing option and the rounded chrome corners are a safety feature to the public. Optional wire baskets for the A Boards are sold separately.



Product Code: AAB

OUTDOOR
MARKETING

Order online www.signwaresystems.co.uk

A Board – Wood Effect

The upscale wood effect A Boards are available in a range of sizes and are perfect for promotional messages. The advertising board is highly portable and is easy to move and store.

Key Features:

- Wood effect in Oak and Pine only with chrome corners for added safety
- Double-sided A Board with snap frame profiles
- Attractive natural designs for advertising and marketing

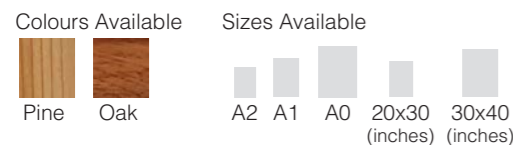

Product Code: AAB-WE



Product Code: AAB-HDR

A Board with Header

The double-sided display board header is available in silver only and offered with the A1 pavement boards. The header features a chrome effect rounded corner for safety, perfect for company logo or branding and allows easy change for corporate messages.

Key Features:

- Silver header as standard and available with various A1 pavement boards only
- Ideal for a premium display with additional branding

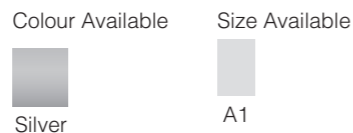

Tubular A Board with Arched Header

The double-sided Tubular A Board is an ideal way for advertising or promoting in outdoor high traffic areas to attract potential customers. Easy to change graphics with the magnetic PET covers, which peel off easily for that quick promotional change. The arched header on the unit offers any business the ideal way to promote their business brand or to use a corporate logo on both sides.

Key Features:

- Pavement sign have heavy steel feet for stability
- Available in different sizes and colours



Product Code: TAB-A



Product Code: TAB

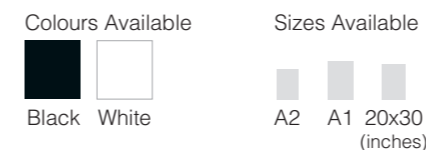

Tubular A Board with No Header

The Tubular A Boards without a header works identical to the other Tubular boards, with a great way to extend your marketing and promotion outside.

Key Features:

- Essential for retailers that are far away from the main road and high streets
- Black and white available in all sizes



PRICES ON OUR WEBSITE



Product Code:
TAB-R

Tubular A Board with Rectangular Header

This double-sided display board with a rectangular header is a great alternative to other pavement signs as they fold away for easy move and storage. The header option allows for corporate branding.

Key Features:

- Available in colours black and white only
- Ideal for corporate branding launch

Colours Available



Black White

Sizes Available



A2 A1 20x30 (inches)

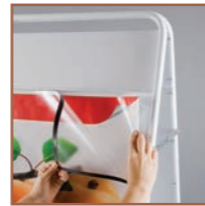

A Board Accessories

Replacement Cover

The covers are UV anti-glare and help to protect the graphics in all weather conditions as well as any potential vandalism. They are ideal for all types of A Boards and Snap Frames. The replacement covers are sold in packs of 2 and available in various sizes.



Product Code: RC

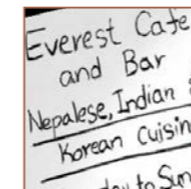

Product Code:
DWP

Dry Wipe Panel

Easy to clean and change your message content with no cost of reprinting. Suitable for all types of A Boards and with most Snap Frames. They are sold in packs of 2.

Chalk Panel

Chalk Panels are ideal for café areas or for any promotional use. They wipe away in seconds and are ready to use for the next message instantly without having to incur printing costs. The Chalk Panels are sold in packs of 2 and available in various sizes for all A Boards and Snap Frames.



Product Code:
CP

Wooden A Boards

The Wooden A Board is great for advertising outside to entice potential consumers. A wooden A Board adds a rustic natural element to your business and can easily be updated throughout the day. It is ideal to use at a café, garden centres or even pubs looking to advertise or promote products of that day.

Key Features:

- Suitable to use in all weather conditions
- Easy foldaway for storage
- Rustic finish to suit many leisure chains

Colours Available



Dark Wood

Sizes Available



Small
50x80
(cm)



Medium
65x110
(cm)



Large
75x140
(cm)



Product Code:
WAB



Product Code: WBD



Wire Leaflet Basket

The wire leaflet basket is fully assembled and can be used to hang on the side of all types of our A Boards, either on one side or both. Ideal as an extra option for leaflet dispensing to the passing trade.

Magnetic Replacement Cover

Our PET Magnetic Replacement Covers are used mainly for our Tubular A Board series. These keep the sandwich boards looking professional and protects the graphics with simple peel on and off the front face.



Product Code: MPC



COST
EFFECTIVE
ADVERTISING

Forecourt Signs

All our Forecourt Signs have a fillable base with the option of either water or sand. They are larger in size, eye catching and operate with the snap frame mechanism. It is also recommended to use anti-freeze or industrial salt for all water base products to protect them from freezing. The outdoor sign boards are built for all weather conditions and are a unique marketing advertising board for quick and easy promotional change. Ideal for high traffic areas with long distance promotion being essential.



Product Code: WFS

Waterbase Forecourt Sign

The Waterbase Forecourt Sign is exclusively in grey and available in standard sizes as well as larger bespoke sizes. Great to use as an outdoor road side marketing to attract potential customers passing by.

Key Features:

- Large outdoor marketing tool to attract passing motorist in high traffic areas
- Available in grey only with extra frame sub-structure

Colour Available



Silver

Sizes Available

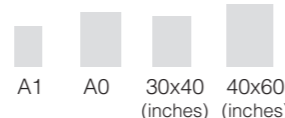

A1

A0

30x40 (inches)

40x60 (inches)



Eco Forecourt Sign

Our waterbase Eco Forecourt Signs offer a more economical and portable display for outdoor marketing. The units have similar features to the Wind Pro version, but on an economic budget.

Key Features:

- Streamlined springs and lightweight for easy relocation
- Cost effective outdoor promotion



Colours Available (frame)



Silver Black*

Sizes Available



A1 A0

*Black colour is only available in A1 size

Product Code:

EFS

Wind Pro Forecourt Sign

The Wind Pro Forecourt sign is available in standard sizes and offers ideal outdoor promotional signage. Attractive and effective unit to suit any retail environment. A Wind Pro Trolley is available to purchase separately.

Key Features:

- Double spring base mechanism and almost fully secure in all weather conditions
- Available in black and grey as standard

Colours Available (frame)



Silver Black

Sizes Available



A1

A0

30x40 (inches)



Product Code: WPFS

Water Fillable Products

The water fillable A Board and Cone stands are stable, heavy and durable pavement signs. These units are commonly used in construction industry to promote safety signs but are also suitable to use at a parking area, play grounds and busy pavement roads.

Each unit has a plastic stopper to pour in either water or sand to make the stand heavier. The product is unassembled but is very easy to assemble with the instruction provided.



Product Code: WBAB
325x570 (mm)

Product Code: WBC
330x385 (mm)

Colours Available



Grey



Product Code: RCO

Oversize Replacement Cover

The oversize covers are UV anti-glare and help to protect the graphics in all weather conditions as well as any potential vandalism and ideal for all forecourt signs. Please call for pricing.

PRICES ON OUR WEBSITE

Menu Boards

The stylish menu boards are suited for indoor use only and supplied with a weighted base for additional stability. This style of poster holder is ideal for attracting audience, managing queues, encouraging passing trade, welcoming guests at events and showcasing at the point of purchase.

- Attractive marketing tool for internal display with UV anti-glare PET front cover
- Fitted with snap frame profiles and manufactured with rounded safety corners for extra protection against passing pedestrian
- Frame can be placed at any height on the upright pole to allow interaction with your customers (on Adjustable Menu Board only)
- Silver anodised aluminium leg

The menu board display units are popular in a range of environments to promote your services or goods. Ideally used in restaurants, cafe's, offices and the leisure industry. The units allow for quick and easy information change for these fast-moving environments. Illuminated menu boards are also available (please call for more information).



Order online www.signwaresystems.co.uk

The Decorative Menu Board

This menu board is a free-standing display stand and an ideal way for queue control and best suited for giving directions. The clip frame feature makes the design flexible in operation for all staff to use and the slight angled frame makes it easy to read at eye level.

- Key Features:**
- Only available in black and silver
 - Available in sizes A3 and A4 in either portrait or landscape

Colours Available: Silver, Black

Sizes Available: A4, A3

Orientation: Portrait, Landscape



Product Code: DMB



Classic Menu Board

The Classic Menu Board display stands have similar features to the Decorative menu stands, but with double legs for extra stability. Manufactured with rounded safety corners for added protection against injuries from passing traffic.

- Key Features:**
- Two-legged feature and heavy base for stability
 - Available in silver and A3 landscape only
 - Supplied with easy mounting instruction sheet and fixing hardware

Colour Available: Silver

Size Available: A3

Orientation: Landscape

Product Code: CMB

Order online www.signwaresystems.co.uk

PRICES ON OUR WEBSITE



Flexible Menu Board

The Flexible Menu Board is multi-functional of various heights, graphic positions and a variety of angles. This stand is an ideal tool for marketing promotional material, perfect for queue control and used in many retail outlets.

Key Features:

- Height adjustable to suit business and traffic areas with orientation option
- Supplied with easy mounting instruction sheet and fixing hardware
- Perfect marketing aid for passing consumers and exhibitions

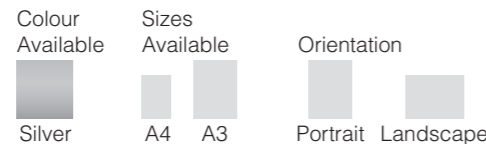

Product Code: FMB

Acrylic Menu Board

This Menu Board is manufactured with heavyweight silicon-edged acrylic with a clear acrylic print holder in a green tint. The display stand is only available in A4 clear and portrait. Full acrylic feature blends into most environments.

Key Features:

- Fully assembled
- Rubber grips on the base for extra stability
- Clear Acrylic Menu Stand gives a clean look to any retail space

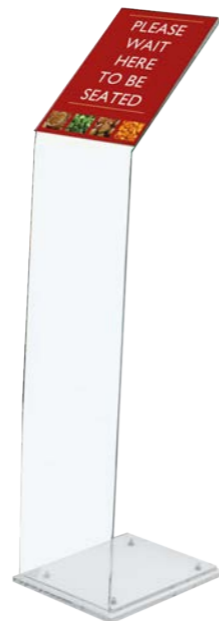
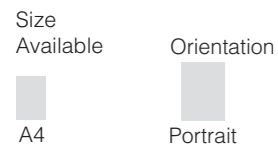

Product Code: AMB

Order online www.signwaresystems.co.uk

Folder Menu Board

This display stand has a transparent acrylic shelf with a ring binder which holds 2 x A4 sizes. It has an added benefit of the option of extra accessories (shelves, dispenser) on the leg to allow maximum use of the stand. The clear shelf feature of the menu board makes the design easy to operate for all staff to use and is free-standing.

Key Features:

- Ideal for catalogue based retailers
- Options for extra shelves/dispenser for extra information
- Ideal for where space is limited



Product Code: FLDMB

The Adjustable Menu Board

The Adjustable Menu Board holds the same qualities as the Decorative Menu Board, the only difference is that the frame is not angled but straight. The adjustable feature allows the business to locate the height of the message at a desired point.

Key Features:

- Available in sizes A3 and A4 in portrait and landscape
- Ideal for press release and promotion in varied environments
- Option of adding extra frames, shelves or dispensers

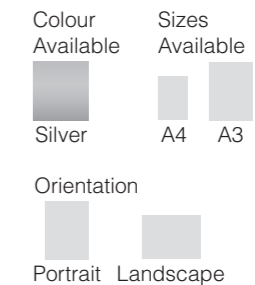

Product Code: ADJMB

Optional Extras:

Acrylic Shelf Steel Shelf Dispenser Snap Frame



Order online www.signwaresystems.co.uk

ENQUIRE
FOR MORE
DETAILS

Brochure Stands

The elegant brochure stands are ideal for promotions and advertising display custom made catalogues or leaflets in the brochure dispensing units.

The multi-purpose display stand is perfect for a wide range of uses from shows, exhibitions, events or shops and office.

- Lightweight and portable design of some models suit trade show functions
- Decorative and larger models suit a permanent fixing on the shop floor and provides extra stability and eye-catching promotional display
- Attractive and professional design with flexibility across the product range
- Supplied with a clear acrylic dispenser and only available in silver
- Aluminium steel frame

Decorative Brochure Stand

The Decorative Brochure dispensing unit is made from a polycarbonate material which makes the product display stand strong, durable and hard to scratch. The product is flat packed and easy to assemble with the instruction guide provided. This can also be purchased with a header panel to create a stopping feature for passing trade.

Key Features:

- Heavy steel base making it suitable to use in public places
- Available in A4 portrait or landscape

Colour Available: Silver
Size Available: A4



Product Code: DBS

Product Code: DBSP



Single Sided
Product Code: BS-S

Sizes Available

8 x A4
12 x A4
16 x A4



Double Sided
Product Code: BS-D

Sizes Available

16 x A4
24 x A4
32 x A4



Wall Mounted
Product Code: BS-WM

Size Available

8 x A4

Brochure Stand Set

The Brochure Stand Set is a smart and professional way to display a variety of brochures. The stand is flat packed and easy to assemble with the instruction provided. The display stand is available in either single-sided or double-sided as well as a single-sided wall mounted set. All transparent 4mm acrylic shelves are supplied with the units.

Key Features:

- Shelves allow full product information display
- Rated best showroom brochure display stand with clean finish to suit most environments

Colour Available

Silver



Rapid Brochure Stand

This is an attractive and stylish product featuring either a 2 or 3 tier of frosted acrylic A4 shelves. Available with a two piece for the header, the front is clear acrylic and the back is frosted acrylic. The product is flat packed for easy transportation.

Key Features:

- Step by step guide on how to assemble the product
- Header panel for extra marketing feature to aid promotion

Colour Available: Silver

Sizes Available

2 x A4 3 x A4



Product Code: RBS



PRICES ON OUR WEBSITE

Pillar Leaflet Dispenser

Introducing a tiered leaflet dispenser to your business is a great way of displaying multiple pieces of literature at the same time. The solid anodised silver aluminium display stand with three tiers is ideal for a wide range of leaflets to be displayed.



Key Features:

- Heavy stable base for public space
- Easy mounting instruction sheet & fixing set

Colour Available



Silver

Sizes Available



3 x A4

6 x 1/3 A4



Product Code: PLD

Portable Zig Zag Brochure Stand

This stunning silver stand is ideal to use in most places, easily transportable and is supplied with a strong aluminium protective carry case. The product does not need to be assembled; you just pull the stand up and lock into place. Fast and effective promotional stand for product promotions.

Key Features:

- Easy to set up and collapse making it ideal for travelling
- Double sided with 6 portrait acrylic shelves
- Sturdy aluminium frame and flat base



Colour Available
Silver

Sizes Available
A4 A3

Product Code: PZZ

Zig Zag Brochure Stand

The Zig Zag stand is extremely modern and eye-catching with a unique look making it visible in any environment. The stand is available either with or without the header.

Key Features:

- Hole caps to cover mounting holes
- Comes with easy assembling instruction
- Portable and easy to store and reposition

Colour Available



Silver

Size Available



A4



Product Code: ZZS



Product Code: NPZZ

Newage Portable Zig Zag Brochure Stand

Attractive and flexible product for events and presentation on the go. The Newage Portable Zig Zag Brochure Stand is a foldable unit with 5 shelves. Does not require any assembling tools as you simply pull up and lock into place.

Key Features:

- Foldable stand while the brochures are still stored in it
- Easy to use, store and transport
- Header arm on the top can be locked to keep the display stable

Colour Available



Silver

Size Available



A4

**POPULAR
BROCHURE
STAND**

Modular Information Stands

Modular brochure stands are a robust free-standing information board. Unique and clever design to display and dispense your promotional materials around your business or use for events, exhibitions and in travel agents. Many combinations are possible by adding to the pole and base, from Banner Arms, Angled Dispenser, Steel Shelves, Side Arm Dispensers, Snap Frames and Slide-in Frames. The Modular information stand is supplied and sold in variable components allowing the businesses to cater their promotions to suit the environment.



Free standing brochure stands have the snap frame mechanism for displaying posters whilst the attachable literature shelf can be used to dispense leaflets, brochures or company information. With the single or double-sided capabilities, the information display board can be used in many environments. The stands are ideal for travel agents and the leisure industries where promotional change is frequent.

Our stands are versatile and can be modelled to display various graphics, just brochures or both at the same time.



Order online www.signwaresystems.co.uk

Modular Stand Pole and Base

The stands pole and base are manufactured with silver anodised aluminium in either 2 or 4 channel options allowing the customer to choose how they want to display or promote information. The 2 base channel allows for front and back display only. The 4 ways channel allows the customer the flexibility to use different angles for the promotions.

Key Features:

- Easy to assemble components to maximise the use of the stand
- Heavy and stable base for high traffic areas and indoor use only
- Each shelf has a capacity of 2 x A4
- Design your own variation

Colours Available



Types Available

2 Channel 4 Channel

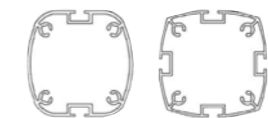

Product Code: MIS

Modular Stand Set Systems

These modular systems are available as standard and each with various accessories attached to the 2 channel pole and base. Stand A incorporates 8 x A4 angled dispensers and a header. Stand B incorporates 8 x A4 side dispenser arms and a header. Stand C incorporates 4 x A4 double steel shelves. Stand D incorporates a banner arm display and 3 x A4 side dispenser arms.

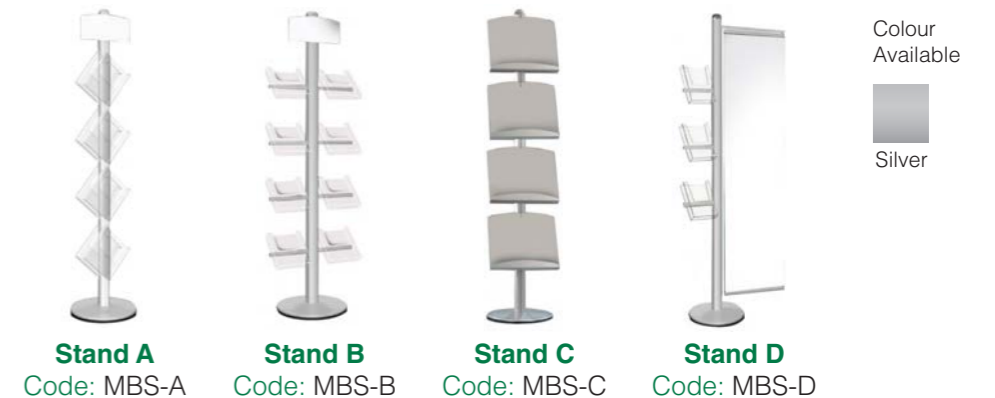

Stand A
Code: MBS-A

Stand B
Code: MBS-B

Stand C
Code: MBS-C

Stand D
Code: MBS-D

Colour Available
Silver

Order online www.signwaresystems.co.uk

Modular Stand Accessories

Modular Header

Ideal to add your business logo (print not included) to the top of the header to make it stand out in large crowds.

Sizes Available

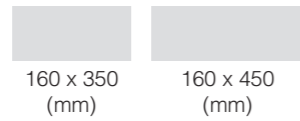

Product Code: MH



Product Code: MAD
Sizes Available

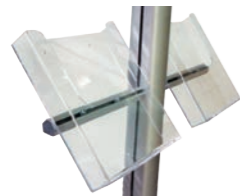

Product Code: MSD
Sizes Available

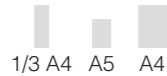

Modular Dispensers

The dispenser gives a modern and attractive look with its unique display. It can hold up to 8x A4 brochures at a time. There are two types of dispensers, an angled dispenser or a side dispenser.

Modular Steel Shelves

Powder coated and 1.2mm thick, the shelves provide plenty of room for content to be displayed. Clean and modern, making the content displayed within the shelves much more eye catching. The shelves can be supplied in various sizes in both portrait or landscape.

Sizes Available



Product Code: MSS

Modular Acrylic Shelves

This product is easy to assemble to the brochure stand with an instruction sheet provided. These shelves are modern and stylish and offer a clean look to your content making them ideal for most businesses. The acrylic shelves are 4mm thick and can be supplied in either portrait or landscape in various sizes.

Sizes Available



Product Code: MAS

Modular Snap Frame

The slim line 30mm trim of the frame gives it a modern and attractive look. The snap frames have rounded corners that offer safety as well as ensuring a professional look. Your posters and custom graphics will be secure with the snap frames own 'Security by Intelligence' feature. This means when closed, all fixings and opening methods are hidden from view. Mitred corner snap frames are available upon request.



Product Code: MSF

Sizes Available



Sizes Available

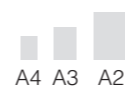

Product Code: MSIF

Modular Slide-in Frame

Offering a clean and attractive look to best suit your promotions, these frames are easy for promotional change with slide in and out feature. Best used with our range of leaflet and poster display stand.

Modular Banner Arm

The poster banner is easy to change. The modular stand with a banner arm are ideal for indoor use.

Sizes Available

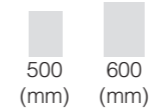

Product Code: MBA

Example Variations Available:

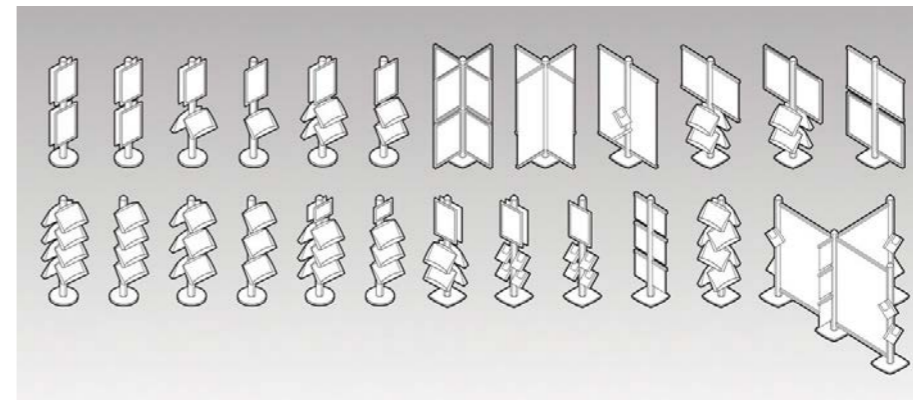

PRICES ON OUR WEBSITE

Order online www.signwaresystems.co.uk

Order online www.signwaresystems.co.uk

Portable Promotional Display

Our various stands are highly portable for promotional display. The roller Banner Stands are an easy roll up design, versatile and cost-effective advertising unit that adds to a great attraction and product promotion for your business. Our Illuminated and Decorative Totems have an excellent and attractive look. It can be spotted from a distance, encouraging potential customers to come closer to look. The Information Boards are suitable for leisure, retail or any public place to display large posters or graphics and ideal for promoting events.

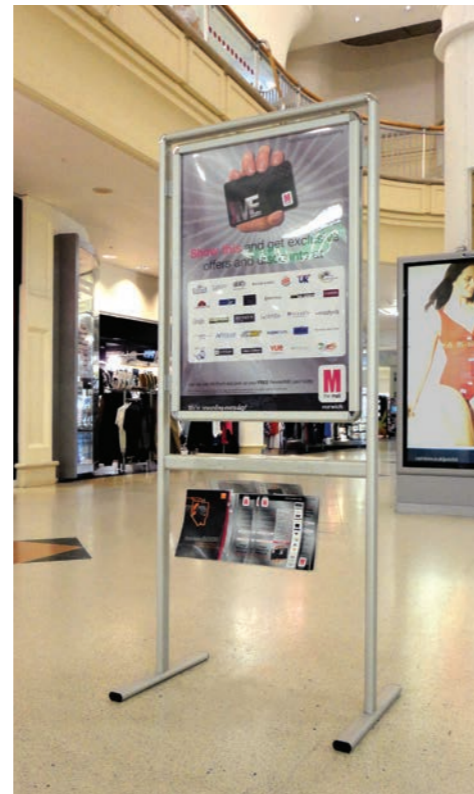

- Banner stands displays high quality banner with your custom branding
- Enhance the visibility of your business
- Ideal for event as a marketing tool or promotional use in public area
- Lightweight and portable, print not supplied

- Totems have an elegant convex design
- Anti-glare PET poster covers (permanently fixed on one edge with a magnetic seal on the other)
- Info Boards are portable and allow easy graphic change

Order online www.signwaresystems.co.uk



Product Code: TLB



Illuminated Totem

This large elegant design is a double sided freestanding poster display for internal use only. The Snap Frame sides allow quick and easy poster change. It has a silver anodised aluminium casing with silver coated steel base.

Key Features:

- Supplied with 2m cable & plug
- CE certificate supplied with each unit
- Fully recyclable aluminium casing, steel base & poster covers

Colour Available Sizes Available (mm)

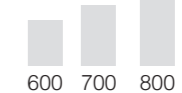

Decorative Totem

The embossed metal effect, the polystyrene panel at the bottom with silver coated steel base, has fluorescent tube lighting (single & double depending on the size). The convex design has a Snap Frame side to allow quick and easy poster change; this is for the top half only.

Key Features:

- CE certificate supplied with each unit
- Fully recyclable aluminium frame, polystyrene panel, steel base & PET poster covers

Colour Available



Sizes Available



Product Code: DTS

Order online www.signwaresystems.co.uk

Info Board Single and Double Sided

Stylish information board is perfect for communicating events, promotions or company news in small floor space areas. The free-standing design is portable and so easy to be moved around to suit your current display or offers. Elegant and robust frame with shiny rounded chrome corners, and 2 snap frames attached together to allow for display to be used as single-sided or double-sided in portrait only.

Key Features:

- Easy to change your poster with a 32mm snap frame mechanism
- Perfect for exhibitions, cinemas and high traffic leisure industries
- Options to add acrylic shelves for literature dispensing

Colour Available
 Silver
 Size Available
 A1



Product Code: IB

Overhead Promotional Signage

The popular overhead promotional signage is key for most retailers for multi store instant promotional changes. These promotional units are made from durable plastic construction which can be updated easily with new prints within minutes. The units are supplied in a standard size and work as an ideal cost-effective alternative to lightbox using the internal shop lighting for illumination.



Key Features:

- Easy to change graphics
- Effective retail marketing with cost benefits
- Lightweight and easy mounting for various ceiling types

Eco Info Board – 1 Panel and Multi Panel





Product Code: EIB



The Eco Info Board 1 or 2 Panel is a double-sided floor standing display. Supplied with a blackout PVC panel to prevent light transmission. Extremely easy to change the poster; simply slide in through the channels on the stand at the top. The unit can be supplied with 1 or 2 tiers, please choose option when ordering.

Key Features:

- Supplied with a poster protective set and black plain sheet
- Easy to change your poster with slide your graphics in and out in seconds from the top
- Product is unassembled but is supplied with easy instruction sheet and fixing elements

Colours Available
 Silver  Black
 Size Available
 A1

Banner Stands

We supply a wide range of retractable banner stands for businesses, which are a good source of instant promotional marketing taking very little floor space. The promotional banner stands vary in heights with some models having the telescoping feature to adjust the promotional sign to suit the needs of the business. On most models, graphics can be stored within the system making the units adaptable and flexible for future use.

Key Features:

- Easy for transportation, store or assemble in quick time
- Great for high traffic areas with instant recognition for the advertisement
- Great promotional banner stand which adds quality to your advertisement at any point
- Single and double-sided models available to suit
- Sizes vary from 600mm to 1000mm.



Product Code: BS

Colour Available
 Silver

PRICES ON OUR WEBSITE

Poster Holders & Grippers

The Poster Holders and Grippers are an ideal tool for advertising your business or services in retail stores, offices or in public areas. Our Poster Holders are available in number of shapes and sizes and are suitable for promotions at a competitive cost to traditional signage.

The Poster Grippers are made from PVC plastic material and can be used to hang your graphic wherever.

Poster holders are indoor use only and help to generate interest in new merchandise or instore promotion. All poster holders and grippers are sold in pairs and can be suspended from ceilings, shop windows and some models can be wall mounted.

For hanging options, to complement the various products, please see our accessories section, page 66/67.



Order online www.signwaresystems.co.uk

Poster Snap

The Poster Snap uses the 'snap open and snap shut' mechanism and comes in pairs with a top and bottom profile. This is to keep heavier and bigger posters secure. The Poster Snaps hold standard paper posters in a range of sizes and are lightweight.

Key Features:

- Suitable for silk-screen printing graphics
- Sliding hangers can be moved to allow for variation hanging points



Rounded profile also available exclusively, please enquire

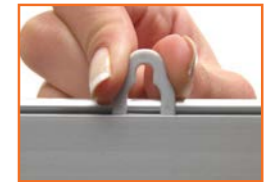
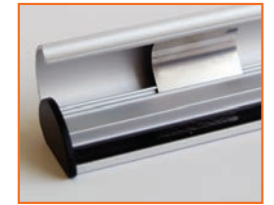

Product Code: PS

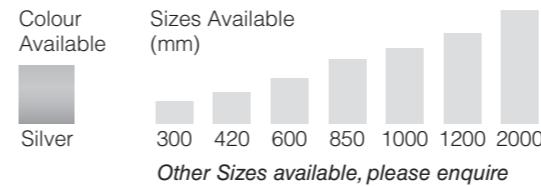

Poster Grippers

Most economical and popular clear plastic banner holder with a 'snap open and snap shut' mechanism.

Key Features:

- Includes two banner rails & two hanging clips
- Lightweight & durable

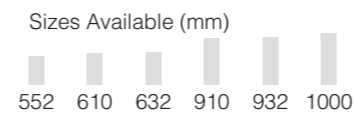

Other sizes available, please enquire

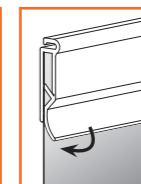
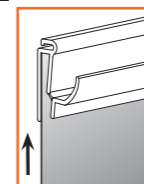
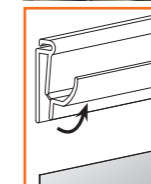
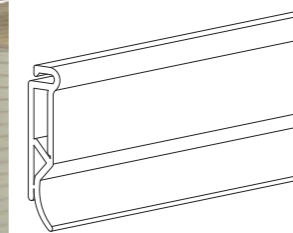

Product Code: US

Gripper Triangle Clips

The clips are suitable for hanging poster bars and can be ordered separately, please enquire.



Product Code: UCTRI



MOST POPULAR HOLDER

Order online www.signwaresystems.co.uk



Poster Clamps

Poster Clamps are aluminium hanging bars designed to grip the top and bottom of posters and banner materials. It is easy to use, and non-spring loaded meaning the poster is clamped down and fixed in.



Key Features:

- Suitable for ceiling suspension and wall mounting
- Easy to change with turning end caps to help slide the poster in

Colour Available
Silver

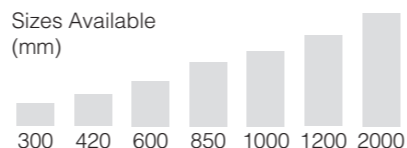

Other sizes available, please enquire

Product Code: PC

Fast Note

The slim and compact design gives the product a modern and attractive look. This Fast Note is great for hospitals, restaurants, hotels and bars, conference rooms and offices. Within the profile, the cylinder allows paper to be held much easier inside and also for content to be changed easily.



Product Code: FN



Key Features:

- Fixing holes on the profile with screw and wall plugs or can be assembled elsewhere with double sided tape (supplied with easy to follow manual)
- Available in various sizes



Product Code: DS



Door Signs

Elegant and stylish Door Signs are suitable for areas such as offices, hospital and schools. The product can be used both as a portrait and landscape sign. The modern attractive door sign uses the same snap mechanism used on snap frames making it easy to change signage.

Key Features:

- Anti-glare PET Cover
- Fixing set & manual supplied
- Various sizes available



Colours Available
Silver Black Pine Oak

Swing Wing

The Swing Wing Base is a modern and attractive silver anodised aluminium holder. The holder is eye catching and can be used in landscape or portrait. The clear acrylic pocket is sold separate to the base.

Key Features:

- Before use, peel off the film over the clear pocket
- The base can be used to add additional logo for your business.
- Various sizes available, please enquire

Colour Available
Silver



Product Code: SW

Acrylic Swing Wing Poster holder must be bought separately.



Poster Trap

The Poster Trap is a smart, effective and an intelligent way to display information. The poster holder is made from powder coated steel with locking nuts for tight vice like grip. The base can be adjusted to various panel thicknesses and can be used in most indoor areas. Various sizes available.

Key Features:

- Maximum height of poster 150cm
- Logo can be printed on both sides of the base (minimum quantity applies)
- Supplied with easy mounting instruction sheet

Colour Available
Silver



Product Code: PT

Easy Swap

The Easy Swap base is manufactured in aluminium profile to hold the poster holder steady and secure to enable the poster to stay up. It has an easily adjustable fixing mechanism underneath the stand making it user friendly. Various sizes available.

Key Features:

- Holds graphic thickness from 5mm to 10mm
- Supplied with easy mounting instruction sheet
- Suitable for indoor use such as schools, seminars, showrooms etc

Colour Available
Silver

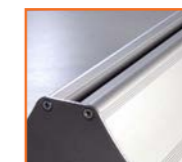

Product Code: EZS

Print Holders & Leaflet Dispensers

All print holders are available in A5, A4 & A3 and can be used in either a portrait or landscape orientation. Popular in fast food industry, the product allows businesses to promote their goods and service at the point of contact.

All the print holders and leaflet dispensers are clear transparent acrylic material.

The Leaflet Dispensers are available in various sizes to accommodate ranging business and product promotions. This product is widely used in attraction and leisure industries and ideal for dispensing of leaflets and booklets.

These are all perfect to aid in various promotion of goods and services offered by the business.

Counter Standing Leaflet Dispenser

- Injection moulded from clear styrene
- Ideal for dispensing leaflets or booklets

Sizes Available
1/3 A4 A5 A4



Product Code: CLD

Multi-Tiered Leaflet Dispenser

- Counter standing leaflet dispenser with 3 or 4 pockets
- Ideal for dispensing a number of similar or different leaflets or brochures

Sizes Available
3 x 1/3 A4 3xA5 3xA4 4 x 1/3 A4

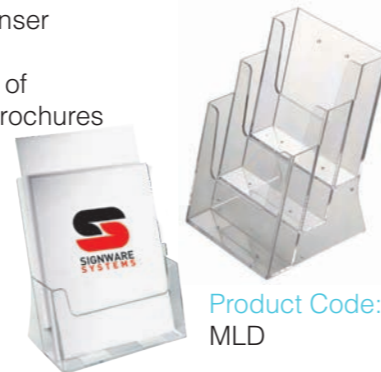

Product Code: MLD

Wall Mounted Leaflet Dispenser

- Perfect for holding brochures and leaflets

Sizes Available
1/3 A4 A5 A4



Product Code: WLD



External Leaflet Dispenser

- Weather resistant leaflet dispenser for outdoor use

Sizes Available
1/3 A4 A5 A4



Product Code: ELD

Business Card Holder

- Counter standing landscape business card holder
- Perfect for displaying your business cards

Sizes Available
90x55(mm)
Orientation
Landscape



Product Code: BCD

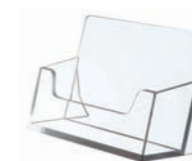

Single Sided Print Holder

- Angled print holder for easy viewing

Sizes Available
A5 A4 A3
Orientation
Portrait Landscape



Product Code: SPH

Double Sided Print Holder

- Upright to view same or different information from either side

Sizes Available
A5 A4 A3
Orientation
Portrait Landscape



Product Code: DPH

Wall Mounted Print Holder

- For adhering to walls or white goods

Sizes Available
A5 A4 A3
Orientation
Portrait Landscape

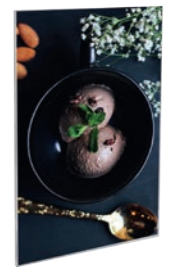

Product Code: WPH



Reel EZ Display System

Exclusive to Signware Systems, our Reel EZ Display system provides a safe, retractable ceiling sign hanging system to many establishments across the Europe and USA. The award winning one component sign hanging systems for all in-store signage is designed and patented in USA.

In line with Health & Safety regulation, the Reel EZ display unit allows one person to change signage from the floor to ceiling at a desired height without the aid of a ladder by using the Reel EZ telescoping pole.

Empower your store staff and work colleagues for promotional change without incurring high cost of using contractors.

Reel EZ Unit

Retractable sign hanging unit, easily attaches to most suspended ceiling tracks. Pre-assembled with hanging hooks and self-levelling bar, the unit can carry sign weight of up to 5lb and 36" wide on a single unit. For wider and heavier signage, we recommend using multiple units.

Colour Available
Cream

Size Available
5lb



Key Features:

- Allows easy POS change with retractable feature
- Self levelling bar ensures signs always hang level
- Adjustable stopper allows for variation in heights
- Can be attached directly to grid ceilings or any type ceiling with our adaptors
- Can be used with poster holders (sold separately)

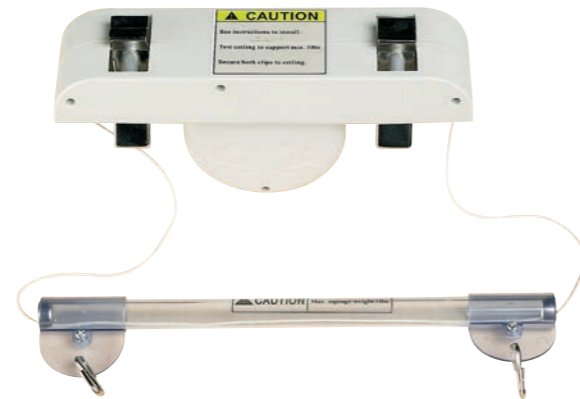

Product Code: RZ

Reel EZ Accessories

The Reel EZ accessories compliment the unit in attaching to most ceiling types. Manufactured to provide the Reel EZ unit with a base to attach to, these components can be used in ceiling types such as open beam, shopping malls and traditional type ceilings. They provide the ideal components to maximise open spaces for sign hanging and promotion.

Reel EZ Pole

To use with Reel EZ unit, telescoping to heights of up to 3 meters, the pole is lightweight and easy to use to bring the sign down from high ceilings. Fully adjustable to reach higher ceiling, they also work as a stopper when changing signs on the unit to minimise retraction without the sign.



Product Code: RZPL

Colour Available
Silver

Reel EZ Cable Adaptor

The adaptor is a U Clamp unit which is suspended from cables at mid height to act as a platform for the Reel EZ unit to attach to. Specially created for very high ceilings, this attachment allows the cable to be dropped up to 8 meters from the top of the ceiling for the easy fixing of the unit at workable level for store personnel.



Product Code: RZCA

Colour Available
White

Reel EZ Swivel Adaptor

Allows the unit to be flexible in directional sign suspension. Clips onto most suspended ceiling struts as well as our ceiling track (sold separately).



Colour Available
White

Product Code: RZSW

Reel EZ Open Beam Adaptor

Offers the flexibility of using on square or round beams for sign suspension: The adaptor attaches to the beams creating a base for the Reel EZ unit to attach to the clamp on the adaptor.

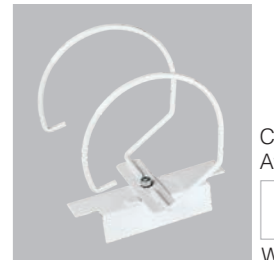

Colour Available
White

Product Code: RZOBC

Ceiling Track

These are ideal for anchoring points for the Reel EZ to be clipped where grid ceiling is non-existent. (To be purchased separately, see Accessories page 70).



Colour Available
White

Product Code: TT48

Cross Beam

The cross beam adaptors enables mid track Reel EZ hanging and graphics to be positioned where desired. (See Accessories page 70 for more detail).

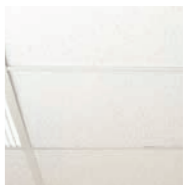

Product Code: CB24

LADDER-LESS SIGN HANGING

Cable Systems

The cable systems are modern, unique and attractive display units for many environments. This allows you to make use of your floor space to create a display that is visible and clean from both inside and out.

They are easy to install and can be attached to the floor, ceiling and wall giving a professional look to any display.

- High impact area display systems for eye catching symmetrical promotions
- Unique way of displaying posters or shelves in window or rejuvenate blank walls and backdrops
- New system of cable toggle end and tracks allows you to shift the whole display without having to drill new holes
- Can be used with the vertical holders to create a product floating display unit

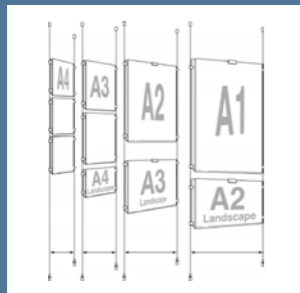

The cable kit is a pre-configured cable display unit to allow you to suspend poster pockets on your walls or windows. Standard cable kits are popular with estate agents, hair salon and shoe shops. These easy to install kits offer retailers large and small a quick and easy cost-effective option.

Cable kits with cable grip holders and acrylic shelves can offer dynamic shelving with cost effective benefits or a floating wall and window display.

Floor to Ceiling Kit

The main component of the cable system is the floor to ceiling fixing with 4m cable and tension floor fixing. Each kit comes complete with an allen key and a set of instruction for easy fixings.



Adjustable Wall Bracket

Designed to be used with our cable system to assist your poster display against the wall. The modern designs and adjustable head of the bracket allows for desired angles and create a desirable wall display. The system can also be used with horizontal grippers and acrylic brochure shelves to create a floating brochure stand.

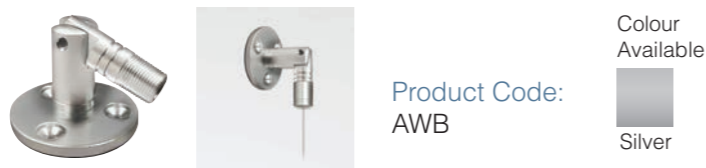

Order online www.signwaresystems.co.uk

Cable Grip Vertical

Our cable grips are available as a single or double grip and they are part of the cable system to hold acrylic poster panels tightly and secure. Double sided grips are unique in offering a continual promotional run.



Single

Stylish and modern, small stature is great while keeping panels together but does not take away any focus and attention from your display.

Double

It has the same features as the single with added benefit of holding thicker panels and in multiple runs at the same time.

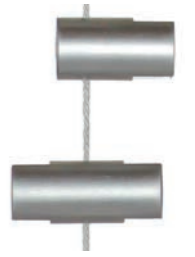

Product Code:
Single: VSG
Double: VDG



Product Code: EAPH

Easy Access Poster Holders

Our Easy Access Poster Holders are clear acrylic pockets to compliment the floor to ceiling cable kit. Easy to use, the poster slides in and slides out of the holder and can be used in windows or on walls. The pockets are available in various sizes and in portrait and landscape.



Easy Access Poster Clips

The Poster Clips are ideal to use with larger poster holder. They are sold in packs of 4's and must be purchased separately. The clip is available from size A2 plus and are essential to use with the poster pocket kits.

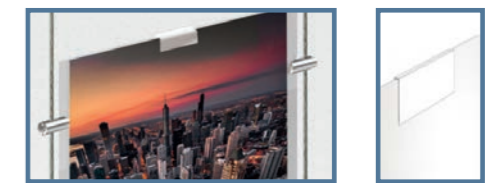

Product Code: EAPC

PRICES ON OUR WEBSITE

Order online www.signwaresystems.co.uk

Cable Set Kits

Cable poster display kits are ideal for hanging signage in windows and offers a way to market and promote your products and are used with our Easy Access Poster Holders.

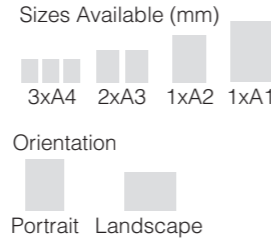

Product Code:
 Ceiling to Floor Cable Set Kits: CFK
 Wall to Wall Cable Set Kits: WWK

Key Features:

- Options to use as a floor to ceiling or wall to wall cable kit
- Streamlined 4m cable has a modern silver anodised finish
- Easy to install, strong and durable cost-effective display

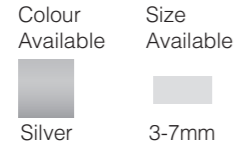

Cable Grip Horizontal

These are available in a single or double grip and used with the floor to ceiling cable kit. The grips are ideal as they grip onto the shelves and leaflet dispensers, offering a flexible and floating display unit. The double-sided grips hold onto the shelves on a continual run display unit.

Product Code:
 Single Grip: HSG Double Grip: HDG

Acrylic Shelves

The acrylic shelves can be manufactured to suit. Available in various thickness materials and tints, they can offer a flexible unique floating wall display unit. Call with sizes for pricing.

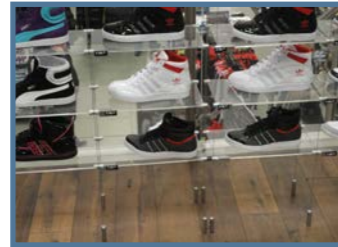

Product Code: AS



Ceiling to Sign Kit

Ceiling to Sign Kit are for suspending signs from the ceiling and is ideal for window displays with limited space. To hold a sign, a minimum of two kits will be required. The bigger the size the more kits you require.

Product Code: CSK

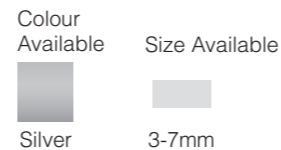

Exclusive Cable System with Tracks

Modern and attractive floor to ceiling floating wall display system with clean and effective selling features. The track and cable toggle system are ideal for shoe retailers as well as customers who require a clean and flexible non-permanent display solution. The display unit uses the standard horizontal or vertical grippers as well as poster pockets or shelves.

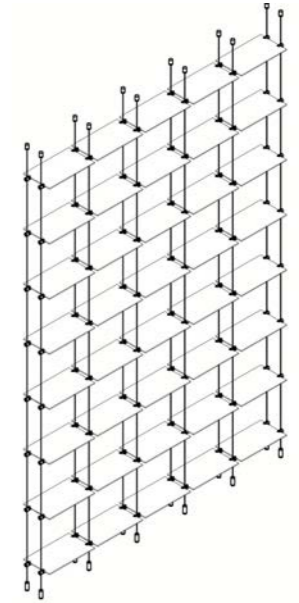

Cable Kits with Toggle Ends

Floor to ceiling cable kits with toggles fixing to be used with track system for a floating look. These cable kits allow the customers to push and move their cables along the top and bottom tracks. Easy to install and maintain, the kits are ideal where a permanent or changeable fixture is a requirement.



Product Code: CS4T

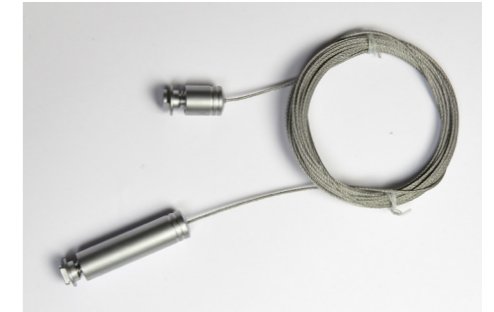

Cable Track

The track system is used for creating a floating display unit which can be easily moved and repositioned without having to re-install the cables. The tracks can be fixed on the ceiling and floor to allow easy movement of a symmetrical display along the whole window or walls.



Product Code:
AL2M

EXCLUSIVE TO SIGNWARE

Flooring Solutions

For your commercial, industrial or residential space get our flooring solutions today. The patent interlocking tiles offer the best industrial and retail flooring solution on the market, boasting outstanding lifetime value to leading retail brands and residential garage floors in over 20 countries worldwide. We offer the finest quality, durable interlocking solutions for all your floors.

Key Features:

- Quick and easy to install
- No damp proof membrane, screed or adhesive required
- Reduces noise and easy to clean
- Non-Slip R-10
- Easy to replace damaged tiles or areas
- Can be used to do encapsulating on asbestos floor



Manufactured interlocking design tiles deal with varied applications to include foot traffic, wheeled traffic and heavy forklift traffic. All floor tiles offer good thermal and acoustic insulation in addition to excellent anti-slip and impact properties.

Please call or email for more information.

Design Tile Collection

The Floor Design Collection is a patented new generation of robust, hidden interlock, loose lay LVT. The Design Collection is available in 8mm and in a modern design with unique colour matching moulding grout edging providing ceramic aesthetics and vinyl performance. Built with anti-fatigue properties, this is one of the most popular floor tiles for retailers.



Floor Tile Excel Hidden Join

Similar characteristics to the design tile, this flooring has a hidden bevelled edge and offering a more traditional vinyl tile appearance. Users range from light foot commercial to high industrial wheeled traffic and available in 5mm, 7mm and 9mm.



Floor Tile Texture Tile

This is our most popular and successful industrial interlocking textured floor tile. Due to the unique and more robust superior dove tail interlocking joint which is almost invisible when installed, meaning it offers a better flooring solution than epoxy/resin. Available in 5mm for light commercial use and 7mm-9mm for heavy industrial warehousing use.

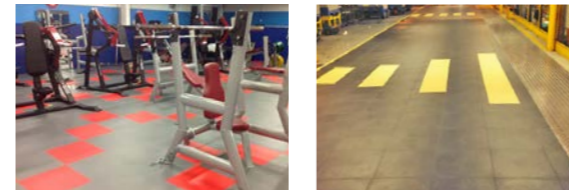

Floor Tile Chequered

The Chequered Plate floor tile is interlocking and has all the same characteristics as our standard textured dove tail tile except it benefits from an interlocking system with matching key ways. When installed renders the interlocking joint virtually invisible resulting in an almost seamless floor.

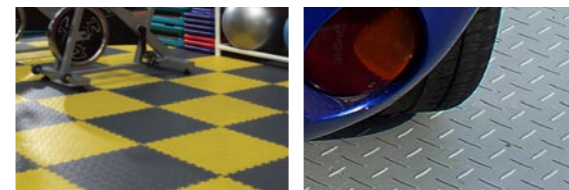

Accessories

The R-Tile range of interlocking floor tiles can also be supplied with edge and corner trims to create a mat area or provide safe and easy access for foot and wheel traffic.

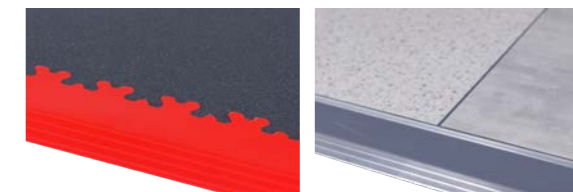

Floor Tile Studded Flooring

This original version of the floor tiling options is still popular with heavy foot traffic areas. It is similar to the floor tile textured floor and manufactured in 5mm and 7mm for light commercial and heavy commercial usage.

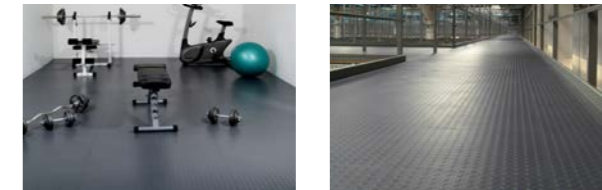

Floor Tile Slate

Slate interlocking floor tile has been developed to satisfy the requirements of commercial, residential and domestic applications and suitable for foot traffic only. The unique Slate surface finish with a hidden joint and bevelled interlock has the appearance of traditional ceramic tiles and the benefits of a vinyl product.



BEST FLOORING SOLUTIONS

Shopfitting

Signware Systems offers top brand shelving equipment to many UK retailers. As a proud partner of Innovag Ladenbau (leading shopfitting suppliers in Germany), we develop realistic concepts for shopfitting and market our design in close co-operation with our customers. Our approach is from the initial contact and idea through to realisation and final acceptance of the solution. Concept design takes the form of a comprehensive approach to projects that includes not only the classical shopfitting business with its shelving systems, but also the planning and performance of all the other activities and skills required for the interior construction work in any retail environment.

Manufactured in a state-of-the-art facility in Germany, we have four key ranges of modular shelving systems to suit many retailers. The award-winning quality and design of the shelving systems will enhance any retail environment such as Food, Non-Food, Bakery, Cosmetics, Wine & Spirits and many others.

Pure System

Manufactured for universal use which is basic, but mature, well thought-out and built to perfection for several years. With varied component list and sizes, depths and pitch, this system is ideal for many types of retailers.

Key Features:

- Most popular and standard shelving system to suit many retailers
- Ideal for supermarkets and convenience store sector with range of adaptability parts to suit
- Available in standard and bespoke colours to suit

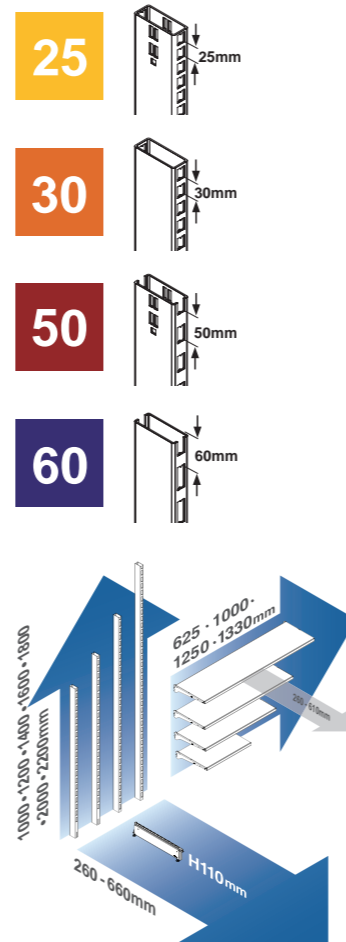

Order online www.signwaresystems.co.uk

Loft System

Offering variable centre and rear panel shelving option for high-quality presentations and is usually found in the wine and cosmetics sector. Complemented by Loft swing and radial shelves and back panels, curved shelving layouts can be realised.

Key Features:

- Creates a dynamic futuristic display unit and offers for LED back panel options
- Ideal for beverage industry wine shops and open product placement displays

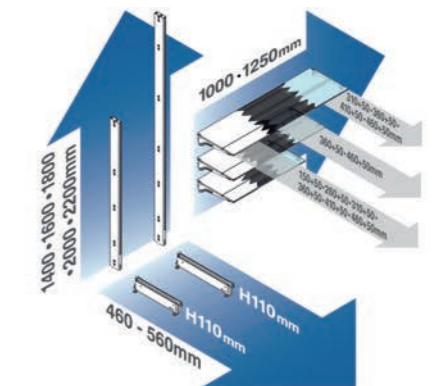

Order online www.signwaresystems.co.uk



Vego System

Free-standing shelving system units for high load bearing. Ideal and highly functional shelving components for those retailers where heavy load display and product placement is a priority.

Key Features:

- Ideal for beverages, hardware and paint shop industry where products are heavy
- In line with health and safety product merchandising and displays with its front support columns

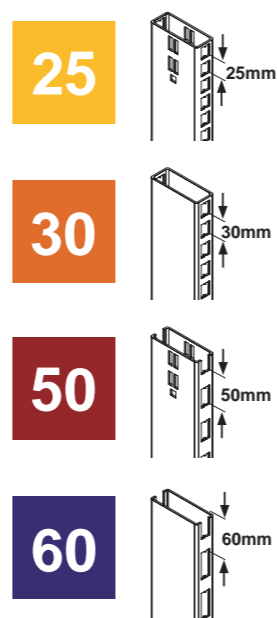
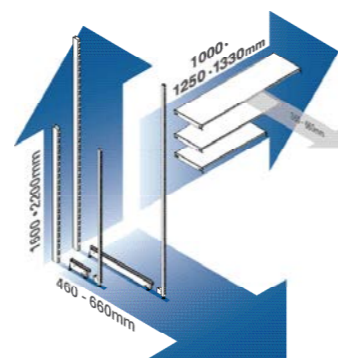
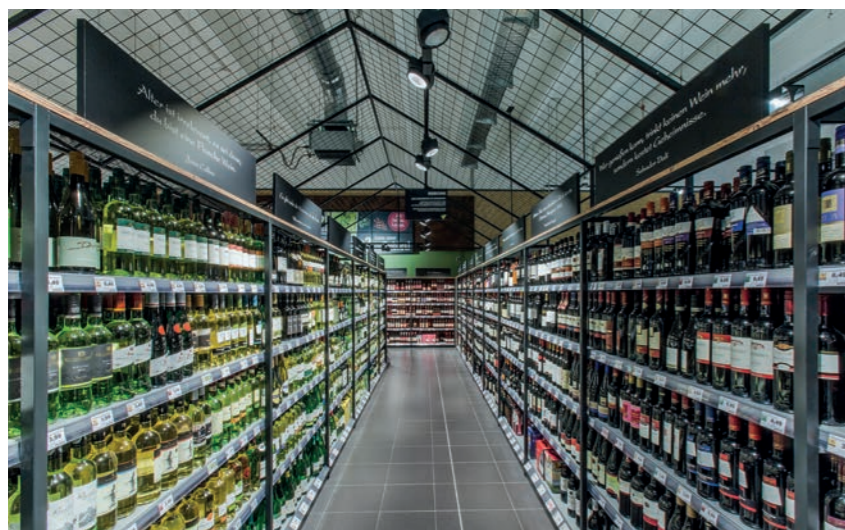

Solid System

Comprises of shelving and gondola designs with a heavy-duty upper cross beam. This shelving or gondola provides room for pallets for merchandising bulk stocks with the 60mm pitch space on the columns.

Key Features:

- Ideal for superstores and white goods industry
- Bulk selling made easy

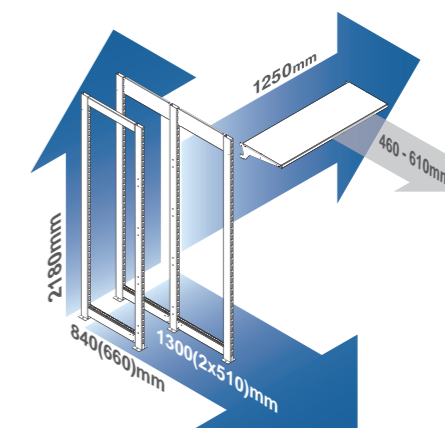
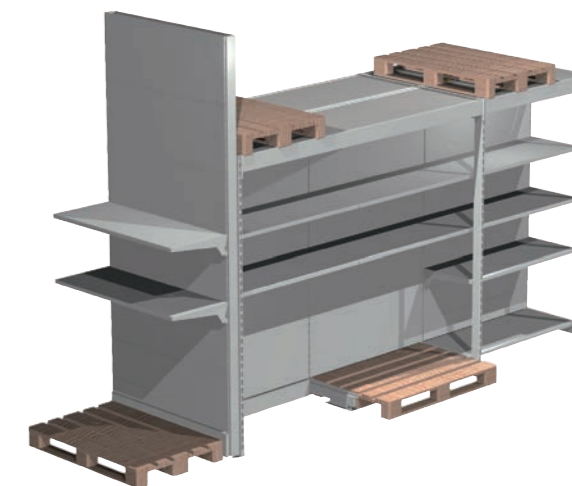

Please visit our website for more details and variation on all the systems or call for an in-depth shopfitting product information and catalogues.



Advertising Mats

Our award-winning range of advertising mats offers businesses a quick and easy solution to promote their products and services at the point of purchase and entry.

Key Features:

- Easy to change graphics, mobile and easy to relocate
- Cost effective printing on paper
- Advertising at various points



DeskWindo

Designed for point-of-sale, this ultra-slim DeskWindo lies snug on the counter surface to clearly display visuals that can be renewed within seconds.

- Face the counter promotion with cost effective benefits
- Ideal marketing tool for fast moving leisure industry and food chains

Sizes Available
A4 A3

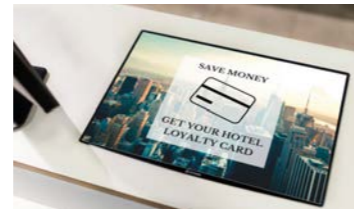

FloorWindo

Effective floor advertising with this easy to use sleek and modern FloorWindo. Enables the business to market and promote brand awareness and drives sales right at the point-of-sale as a graphic feature to direct customers to their product.

- Easy to change graphics with open peel window
- Water resistant from wet shoes and high traffic areas

Sizes Available
4 x A4 A1

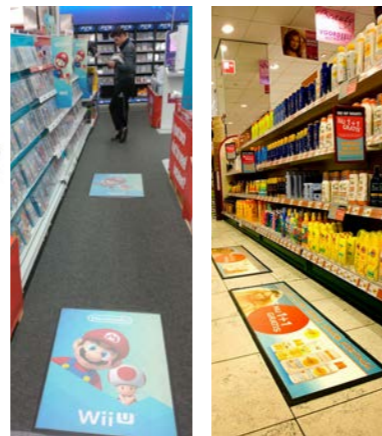

Wire Mesh Basket & Trolleys

Available in various weight configurations, these are great for all types of retailers even those where store aisles are tight (child seat is optional, please enquire). Wire baskets can be made with colour code handles to suit.



Environmental Trolleys and Baskets

This range is made from plastic and manufactured with anti-bacterial property for lifetime of the product. The trolleys are light weight and easy to manoeuvre without compromising on the load bearing.



Shopping Trolleys and Baskets

High quality shopping trolleys and baskets which are modern, attractive and manufactured in the UK and EU. The range of trolleys and retail baskets can be supplied with colours to match to your brand requirements, from chrome finish high quality wire trolleys to a plastic soft finish basket.

Some trolley handles can be logo branded for a more corporate identity and baskets can be colour coded (minimum order applies).

Our 34-litre black shopper is 100% recyclable material for those retailers wishing to do their part.

SEE OUR FULL RANGE ONLINE AT WWW.SIGNWARESYSTEMS.CO.UK

Accessories

Our various accessories help businesses to display and product mount their range of goods in a unique and attractive method. From handbag stands to euro hooks, we offer businesses a wide range of merchandising equipment to help sell and market their product range.

Our wide range of store ceiling fixings and anchors offers businesses the unique accessories for hanging and suspending or window mounting their promotions and graphics. From double ended hooks, adhesive hangers to magnetic ceiling discs and magnets, there is a solution for most hanging methods.

Our range of hooks and anchors are available to order as per request. With specific hanging and merchandising option dependent on product placement, there is a variety of solutions to aid businesses to promote your goods in an attractive and clean look.

Display Accessories



Display Hooks

Improve your all-round POS display by using the set length double ended hooks to create an even and universal look. Display hooks for every occasion are available in various sizes.

Product Code:
C Hooks: C100 Double Ended Hooks: DH

Colour Available



Silver

Size Available

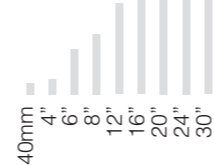

S Hooks

Curved hooks used for general hanging applications for POS or garments. Manufactured in 2mm galvanised wire and packed in 100's (minimum order quantities apply).



Product Code: SH

Colour Available



Silver

Sizes Available (mm)

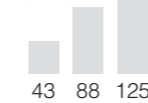

Other sizes made to order, minimum quantities apply.

Adjustable Cable Kit

Sign hanging with varied adjustable heights. Kit comprises of 2 galvanised steel wire with fixed loop on one end and 2 x adjustable slide toggles with zinc alloy hook ends.



Product Code: ACK-2



Product Code: ACK-1.5

Colour Available



Silver

Size Available (mm)

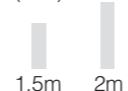

Order online www.signwaresystems.co.uk

Magnetic Ceiling Hook

Strong and powerful magnets which hold to most ferrous metal surfaces, ceiling and other structures. Load strengths vary from 2kg – 25kg and some magnets can be used with the RoPole installation tool.



Product Code: MH

Size	Shape
2kg	■
7kg	●
10kg	●
18kg	●
25kg	●
15lb	■



Ceiling Anchors

Attractive clear ceiling anchors can be attached to suspended metal ceiling struts to avoid damage to tile ceiling when hanging POS. Anchors can also be used with our RoPole system to minimise use of ladders. Available in 45- and 90-degree hanging angle and can be used with our T Track and cross beam system.



Product Code: SCA

Colour Available



Clear

Size / Angle Available

1-pc	45°
2-pc	90°

RoPole

1-up installation tool to use for hanging your POS to grid and metal ceilings. To be used with our clear ceiling anchors and magnets. The pole is telescopic with intermediate variations in height adjustments and has interchangeable heads.



Sizes Available



Product Code: RP

Order online www.signwaresystems.co.uk

Magnetic Discs

These anchor discs are available in two types. Standard metal disc with adhesive to provide attractive base for magnetic hooks for non-metal ceiling. White metal disc with recessed hole to be fixed into non-magnetic ceilings providing a permanent base for magnetic hooks.

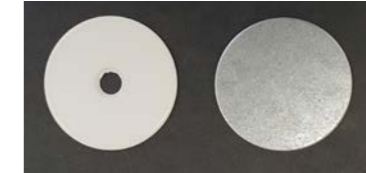

Product Code: MD

Ceiling Clips and Buttons

To be used on grid ceiling or traditional plaster board ceilings. Please visit our website for more details.



RoPole Heads



Product Code: RPH

Replacement heads for the RoPole available to purchase separately.

PRICES ON OUR WEBSITE

Merchandising Accessories

Our range of hooks, arms and stands are available to order as per request. With specific hanging and merchandising option dependent on product placement, a variety of solutions are available to aid businesses to promote your goods in a clean and attractive fashion.

S Hook Ball End

Product merchandise for high fashion retail outlets to general window merchandising and offers a variety of hanging solutions, i.e. Jeans. These hooks are available in various thickness and can be made in a variety of finishes. Please call for more information (minimum quantities apply).



Product Code: SHBE

Euro Hooks

We have a wide range of single- and double-euro hooks for pegboard and slatwall available to order. Ranging from different sizes and in product variations we will always find a solution suitable to your needs. Please call with your enquiry.



Order online www.signwaresystems.co.uk

Merchandising Arms and bars

Our range of arms and bars include, notched arms, sloping arms, garment hooks, stepped arms, oval rails, D bars, P bars, Back bars etc. These products are suitable for clothing displays, garment merchandising and general fashion accessories display. Please enquire with the relevant product placement needs.



Merchandising Stands

We also supply a range of merchandising and display stands for retail environments such as garment rails, hat stands, tie display stands, variable waterfall stands and bespoke items to customer requirements.



PLEASE
CALL FOR
PRICING

Order online www.signwaresystems.co.uk

Other Accessories

Ceiling Track

Manufactured in aluminium and finished in white 25mm profile. The track is unique product to allow the business to create a suspended ceiling position for hanging and displaying promotions or products and eliminates the need to screw or make permanent fixing points.

Key Features:

- Promote window or in-store anchor points for flexible displays and hanging POS
- Use of multiple tracks can aid in creating a 3D effect of multi layers of promotions
- Easy to move POS or merchandise with the use of our ceiling anchors which are movable on the tracks

Colour Available
White

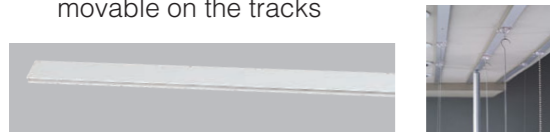

Product Code: TT48

Cross Beam

Manufactured in aluminium and finished in white 25mm profile. The cross beam can easily be mounted between ceiling tracks to create an anchor point between suspended ceiling tiles.

Key Features:

- Easy to locate on the grid ceilings and easy to remove
- Allows the hanging of items or graphics at mid points as a non-permanent fixture
- Ideal for end of gondola units for product promotions



Product Code: CB24

Suction Cups

Our suction cups eliminate the need for blu-tak or adhesive on most glass surfaces. Best aid for glass mounting of graphics and other promotional items for all retailers and are designed for easy application.

Please test all suction cup application prior to use

With Hook

Sizes Available (mm)

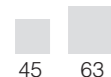

45 63

With Thumb Tack

Sizes Available (mm)

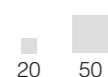

20 50

With Sign Holder

Sizes Available (mm)

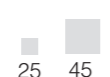

25 45



Wall Panel Supports

The Wall Panel Supports allows you to hold your acrylic poster panel in place, tight and secure. The poster needs to be placed between two acrylic panels then screwed in the thumbscrew and attached to the panel by hand. This product is available in various sizes.

Shoe Shop Accessories

Merchandise your products and shoes exactly the way you want with our eye-catching accessories. Various acrylic merchandising display items are available from shoe step display, slatwall shoe shelves, acrylic bridges and shoe stands. Please enquire.



Brilliant Clips

Brilliant and Clever clips are an ideal way for showcasing your products to suit your business needs.

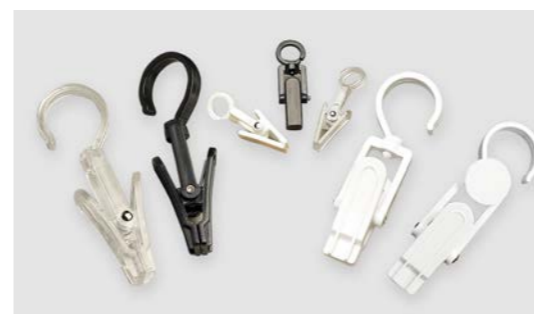

Branding Blocks

Acrylic blocks are suitable for marketing your display and your logo can also be added to for a more premium look. Various sizes and finishes available.



PLEASE CALL FOR PRICING



SIGNWARE
SYSTEMS

Tel : 0116 2681881

Web: www.signwaresystems.co.uk

Email: sales@signwaresystems.co.uk

Signware Systems Ltd
9A Victoria Road North
Leicester
LE4 5EX

Company No: 5716970